

# cavity tray detail

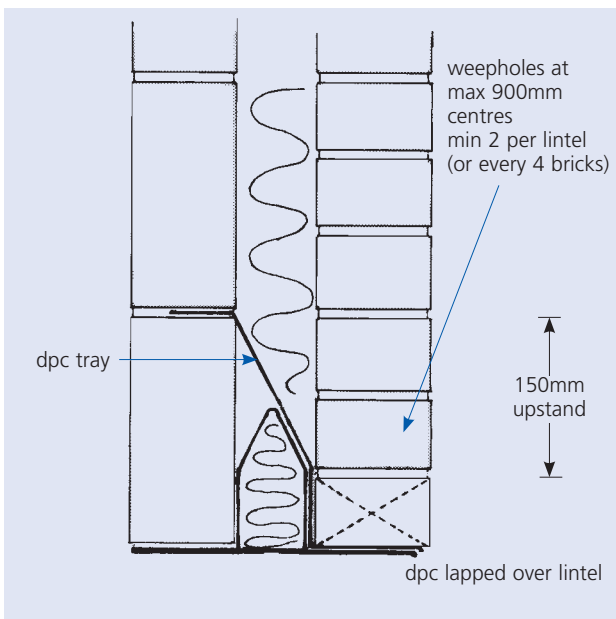

**Typical cavity tray installation**

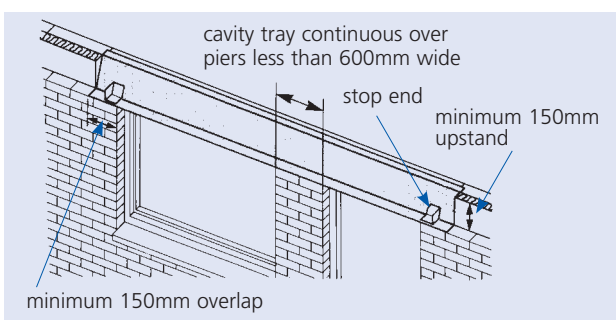

**Cavity tray continuous over a pier**

Cavity trays should have stop ends to prevent water running into cavity.

Weep holes to be provided, minimum 2 per opening and not more than 4 bricks apart.

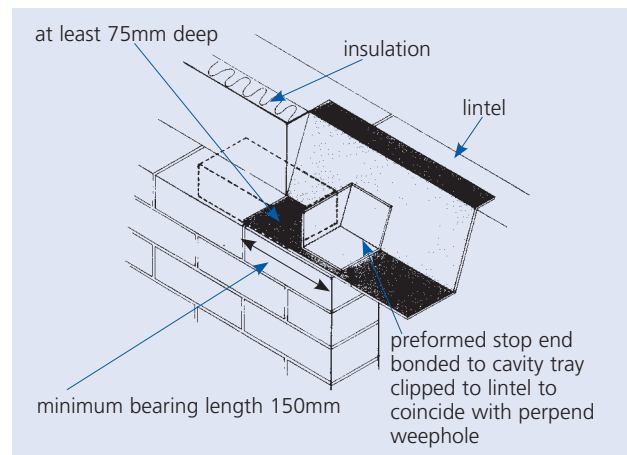

**Stop end**

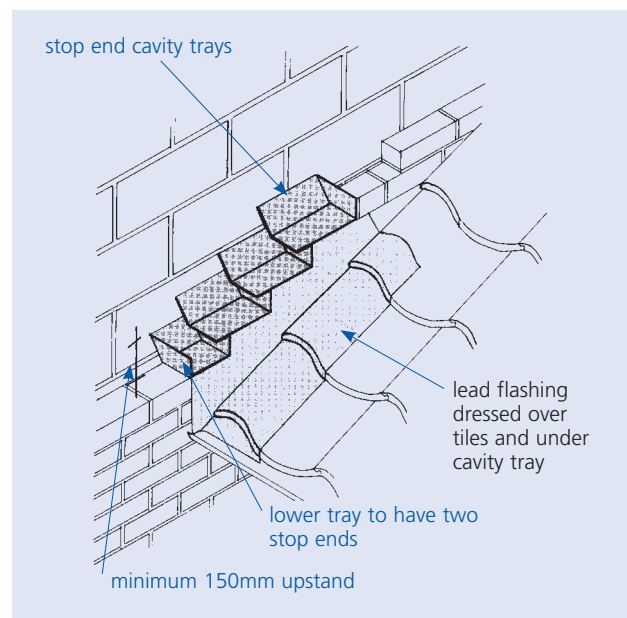

**Stepped cavity tray detail at roof/cavity wall abutment**

A stop end and associated weephole must be provided to the bottom cavity tray.

Lead flashing must be dressed **under** the cavity tray.

# vertical DPC detail

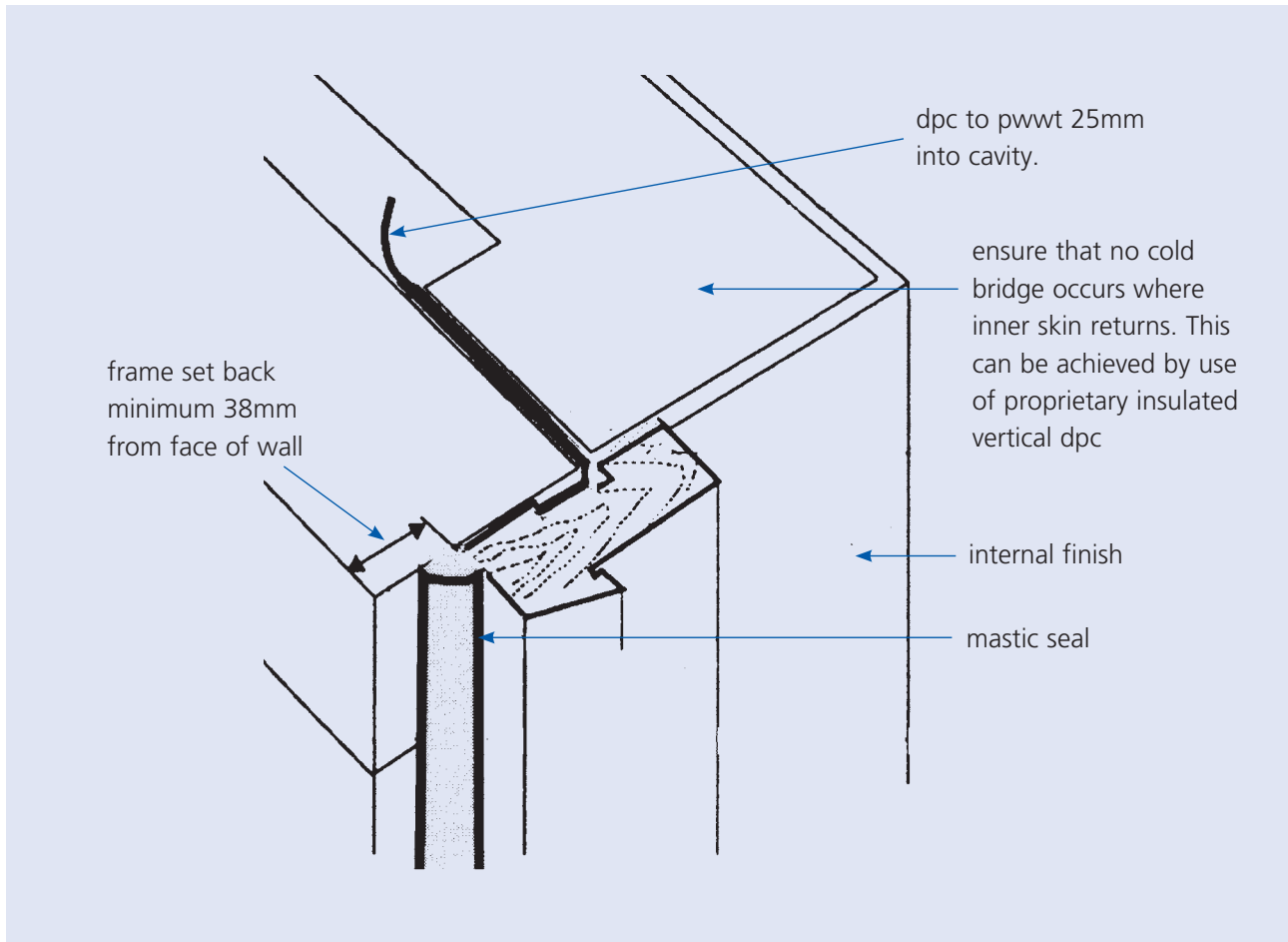

## Typical detail for moderate exposure

- Ensure no cold bridge where inner skin returns.
- Check details carefully for 45° bay windows.
- Frame to be set back if severe exposure conditions exist.
- To comply with Building Regulations Approved Document Part L 2002 the use of proprietary insulated cavity closers installed strictly in accordance with the manufacturers recommendations are advised by 'Robust Details' produced by the ODPM.

## Zurich Building Guarantee

Zurich House, 2 Gladiator Way, Farnborough, Hampshire, GU14 6GB.  
Telephone 01252 377474 Fax 01252 372989 Email [building.guarantee@uk.zurich.com](mailto:building.guarantee@uk.zurich.com) [www.zurich.co.uk/buildingguarantee](http://www.zurich.co.uk/buildingguarantee)  
Zurich Building Guarantee is a trading name of Zurich Insurance plc. A public limited company incorporated in Ireland. Registration No. 13460.  
Registered Office: Zurich House, Ballsbridge Park, Dublin 4, Ireland. UK Branch registered in England and Wales Registration No. BR7985.  
Authorised by the Irish Financial Regulator and subject to limited regulation by the Financial Services Authority. Details about the extent of our regulation by the Financial Services Authority are available from us on request. FSA registration number 203093. These details can be checked on the FSA's register by visiting their website [www.fsa.gov.uk/register](http://www.fsa.gov.uk/register) or by contacting them on 0845 606 1234.  
Communications may be monitored or recorded to improve our service and for security and regulatory purposes. © Copyright – Zurich Insurance plc 2009.  
All rights reserved. Reproduction, adaptation or translation without prior written permission is prohibited except as allowed under copyright laws.