

best practice sheet – rendering (continued)

background	exposure*	first basecoat		second basecoat		finish	final coat	
		designation	thickness (mm)	designation	thickness (mm)		type	designation **
metal lathing	very severe/ severe	I	3 – 6	II	10 – 14	–	roughcast buttercoat for drydash tyrolean	1:1/2:3:1 1/2 II II
	moderate/ sheltered					thrown	roughcast buttercoat for drydash tyrolean	1:1:3:2 III II
						troweled	woodfloat scraped patterned tooled	IV
strong to moderate	very severe/ severe	II	8 – 12	II	6 – 10	–	roughcast buttercoat for drydash tyrolean	1:1/2:3:1 1/2 II II
	moderate/ sheltered					thrown	roughcast buttercoat for drydash tyrolean	1:1:3:2 III II
						III	8 – 12	–
moderate to weak	very severe/ severe	III	8 – 12	III	6 – 10	–	roughcast buttercoat for drydash tyrolean	1:1:4:2 III II
	moderate/ sheltered					thrown	roughcast buttercoat for drydash tyrolean	1:1:3:2 III II
						troweled	woodfloat scraped patterned tooled	IV
weak	sheltered only	IV	8 – 12	–	–	troweled	woodfloat patterned	V

* reference to the map on page 151 of the ZBG Technical Manual with regard to wind driven rain index and exposure ratings.

** where (designation) a mix is specified it is by volume using cement:
lime: sand: coarse aggregate.

The mix for each successive coat should never be stronger than the previous coat or background.

A strong background is deemed to be a dense concrete block, lightweight blocks are classified as moderate, with bricks being moderate to weak depending on type and condition (always check with the manufacturer prior to rendering).

Nominal overall thickness expected for three coat applications is 20mm and 16mm for two coat applications.

For very severe and severe exposures and when the background is metal lathing it is recommended to provide two base coats thus providing an enhanced resistance to rain penetration.

Refer to table 2.14 of the ZBG Technical Manual for mixes relative to designation.

Mortar specification for background exposure and finish

Zurich Insurance Company Building Guarantee

6 Southwood Crescent, Farnborough, Hampshire GU14 0NJ

Telephone 01252 377474 Fax 01252 372989 Email building.guarantee@uk.zurich.com www.zurich.co.uk/buildingguarantee

Zurich Municipal is a trading name of the Zurich Insurance Company. A limited company incorporated in Switzerland

Registered in the Canton of Zurich No. CE-020.3.929.583-0 UK branch registered in England No. BR105

Authorised and regulated by the Financial Services Authority. UK Registered Office: Zurich House, Stanhope Road, Portsmouth, Hampshire P01 1DU

best practice sheet – rendering

Rendering should be in accordance with BS 5262 and workmanship in accordance with BS 8000. In particular it should consider the following:

Movement joints

- Movement joints formed in the substrata must be continued through the render. These are usually at the following centres: 12m for clay brickwork; 7.5-9m for calcium silicate and concrete brickwork; 6m for concrete blockwork.
- Abutments between render and other cladding materials should be weather tight and allow for differential movement.
- Movement joints should be installed at every 5m intervals for metal lathed backed renders.

Metal lathing, angle/stop beads and associated fittings and fixings:

- Must be mechanically fixed with non-corrosive drilled or shot fired fixings
- Must be preferably stainless steel or other non-corrosive materials, not galvanised.

Render application of undercoats

- Before application check the substrate for:
 - Avoid mixing block and brick types to ensure a consistent background.
 - Excessive moisture – allow to dry before application.
 - Excessive suction – if the background is particularly porous then it should be dampened.
 - If the background requires any special treatments, primers etc they must be used in accordance with manufacturer's recommendations.
 - Provide an adequate key to brickwork and some blockwork by raking out joints 8-12mm.
- Positioning of movement joints to be established prior to application.
- Weep holes or air vents formed to drain or vent cavities must be continued through the render.
- Render must not be allowed to bridge any horizontal damp proof course or membrane.
- Render to be applied in two or more layers of the correct thickness and ruled off with a straight edge between grounds.

- Finish with a wood or plastic float and, unless specified, comb to provide a key for the next layer. Render to finish at dpc.
- Each coat should be allowed to shrink and dry out naturally over a period of several days.
- Before applying any coat, the back ground or subsequent coat should be brushed to remove dirt and loose particles of sand.

Render application for the finish coat

- Apply in a single, continuous operation for each wall.
- Positioning of movement joints to be followed through from previous layers.
- Weep holes to be cleared of excess render to allow draining and venting of cavities.
- Finish to a reasonable plane, visually uniform surface, to be able to accept other specified trims or finish where applicable.

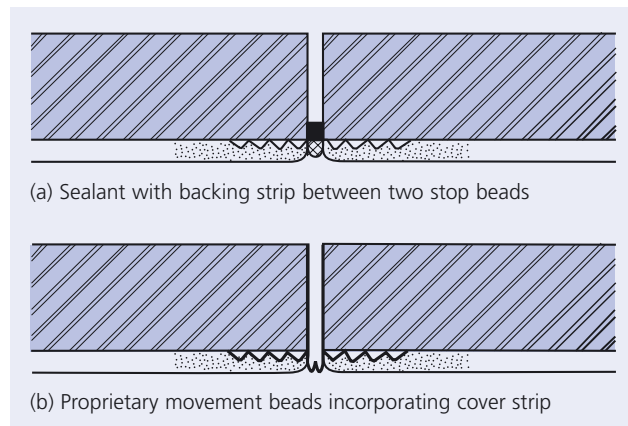

Movement joints in rendering aligned to movement joint in background

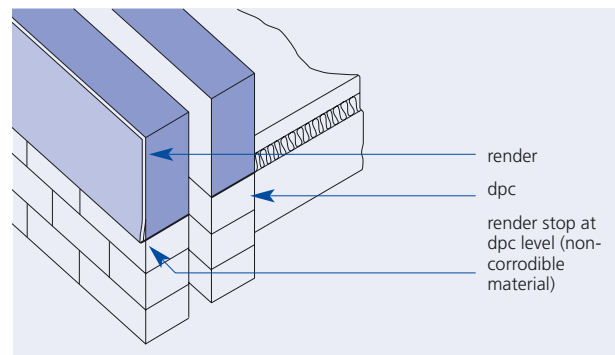

Render to finish at dpc

best practice sheet – rendering

(continued)

Protection of render

- a) In hot weather the render should be shaded to prevent rapid drying. When the rendering has been applied it should be prevented from drying out for two or three days until the mortar is hardened. In drying winds it may need to be kept damp by gentle spraying.
- b) Air temperature should be at least 5°C at the time of application. However, rendering should not be attempted if there is a risk of frost.
- c) Rendering should not be carried out when rainfall exceeds the lightest of showers.

Proprietary rendering systems:

- a) Should possess third party accreditation acceptable to Zurich Insurance Building Guarantee. However, a 20-year, insurance-backed guarantee may be acceptable but prior agreement must be reached.
- b) Should be fixed by approved installers in accordance with the third party accreditation.

Additional precautions for Timber frame

- a) Maintain cavity width of 19mm for water-resistant backed metal lathing (and proprietary render systems) and 50mm for unbacked.
- b) A dpc to be provided between unbacked render and timber battens.
- c) Battens to be either 25 x 38mm or 50 x 50mm preservative treated and fixed in accordance with the recommendations of BS 5262.
- d) Battens to be fixed through the sheathing into the structural timber with annular ring nails. The length of nail to be twice the batten plus the sheathing thickness. Nails should be stainless steel or similarly durable material.
- e) Where cavity barriers are required they should be installed correctly to avoid gaps and fixed with durable fixings ie. stainless steel.
- f) Maintain settlement joints below external frames and soffits.

Batching and storage of materials

- a) Sand for rendering should be stored separately and:
 - Be well graded, having a good mix of coarse and fine particles and comply with BS 1199.
 - Finer sands used for final coats with tooled finishes. Coarser sands to be used for final coats with scraped finishes.
 - Should not be frost bound.
- b) Cement should be stored dry ready for use. Cement and limes should comply with BS 12, BS 146 or BS 4027.
- c) Admixtures and adhesives should only be used when specified and in accordance with the manufacturer's recommendations. Plasticizers should comply with BS 4887-1.

Render mixes

It should be noted that an appropriate mix must be specified to avoid later failure. Particular care should be taken that the mix considers the following criteria:

- a) The background or substrate to which the render is applied. The mix should not be stronger than the background that it is applied to. Mixes to subsequent coats should not be stronger than the previous. Extra care should be taken when rendering aircrete blockwork and manufacturers of those types of blocks should be consulted.
- b) The exposure of the development.
- c) The type of the constructional element to be rendered ie. chimneys.

* For further guidance please see page 3

best practice sheet – rendering

uses	designation	proportions by volume		
		portland cement: lime:sand	air-entrained portland cement:sand	masonry cement: sand
To produce a strong relatively impervious finish but with high drying shrinkage, hence susceptible to cracking. Restrict its use to first base for metal lathing.	I	1:1/4:3	–	–
To provide a suitable render for finishing and base coats in the majority of cases. More permeable than designation 1, and hence has lower drying shrinkage problems.	II	1:1/2:4-4 1/2	1:3-4	1:2 1/2-3 1/2
	III	1:1:5-6	1:5-6	1:4-5
	IV	1:2:8-9	1:7-8	1:5 1/2-6 1/2
Only suitable for work in sheltered locations with weak backgrounds. Ideal for use in remedial works to weak lime based renders	V	1:3:10-12	–	–

Follow the guidance given regarding batching, admixtures, working life and cold weather working for mortars.
Ensure the render coat does not bridge the dpc.

Recommended mortar mixes for use in render finishes

Chimneys, parapets, retaining walls and walls below dpc level

- Pay special attention to the render mix specification and use sulphate resisting cement.
- It is recommended that the backs and exposed horizontal surfaces of parapets are not rendered.
- Throats or drips to copings of parapets and chimneys should project beyond the finished faces to throw water clear.
- Rendering to chimneys should only be carried out where brickwork contains little or no sulphates. Spatterdash treatment should be used.
- As before horizontal dpcs and dpms must not be bridged.
- It is recommended that rendering is not used below dpc. However where this is not practical, the render must still not be allowed to bridge the dpc. A bellcast must be formed in the render above the dpc.

Other construction detailing

- Ensure that drips and throating to cills copings etc project beyond the face of the finished render.
- Notwithstanding wind loadings, the larger the eaves overhang the better. This will provide protection to the top joint and prevent rainwater percolating behind the render.

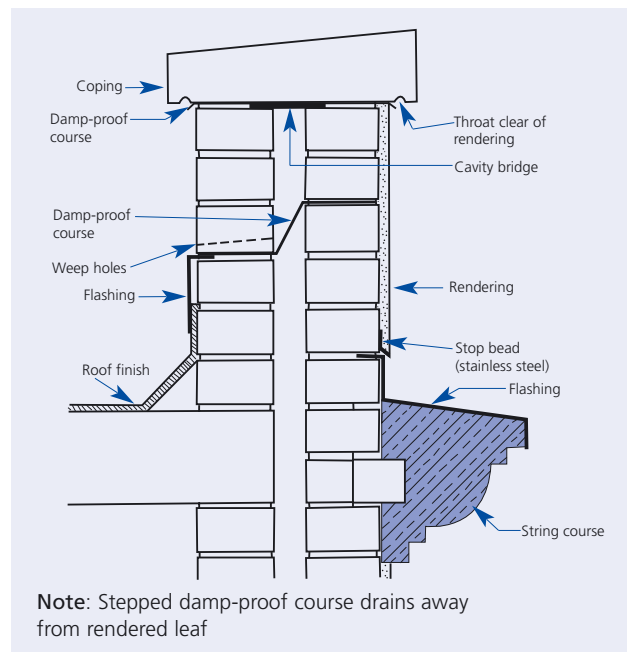

Parapet and string course detail