

notching and drilling details

Clear span of joist* (m)	Holes to be drilled only within the zones of A–B (distance given is taken from either supporting wall in mm)		Notches to be taken out only within the zones C–D (distance given is taken from either supporting wall in mm)	
	A	B	C	D
1.50	375	600	105	375
2.00	500	800	140	500
2.50	625	1000	175	625
3.00	750	1200	210	750
3.50	875	1400	245	875
4.00	1000	1600	280	1000
4.50	1125	1800	315	1125
5.00	1250	2000	350	1250
5.50	1375	2200	385	1375
6.00	1500	2400	420	1500

Notes:
*Clear span is the distance between supports
A = 0.25 x clear span B = 0.40 x clear span
C = 0.07 x clear span D = 0.25 x clear span

Depth of joist 'd' (mm)	Max. depth of notch 0.125d (mm)	Max. diameter of holes 0.25d (mm)	Min. distance between holes* (mm)
100	12.5	25	75
125	16	31	93
150	19	37.5	112.5
175	22	44	132
200	25	50	150
225	28	56	168
250	31	62.5	187.5

Notes: *distance given is when using maximum permissible hole size.
If the joist depth is greater than 250mm, notch and hole sizes should not exceed those given for 250mm deep joists.

Maximum depth of notches and diameter of holes in joists

Permitted locations for notching and drilling joists

If in doubt **ask**.

Adjacent holes must not be closer than 3 times the maximum permitted hole diameter.

A notch and a hole must be at least 100mm apart measured on the centre line of their joist.

notching and drilling details

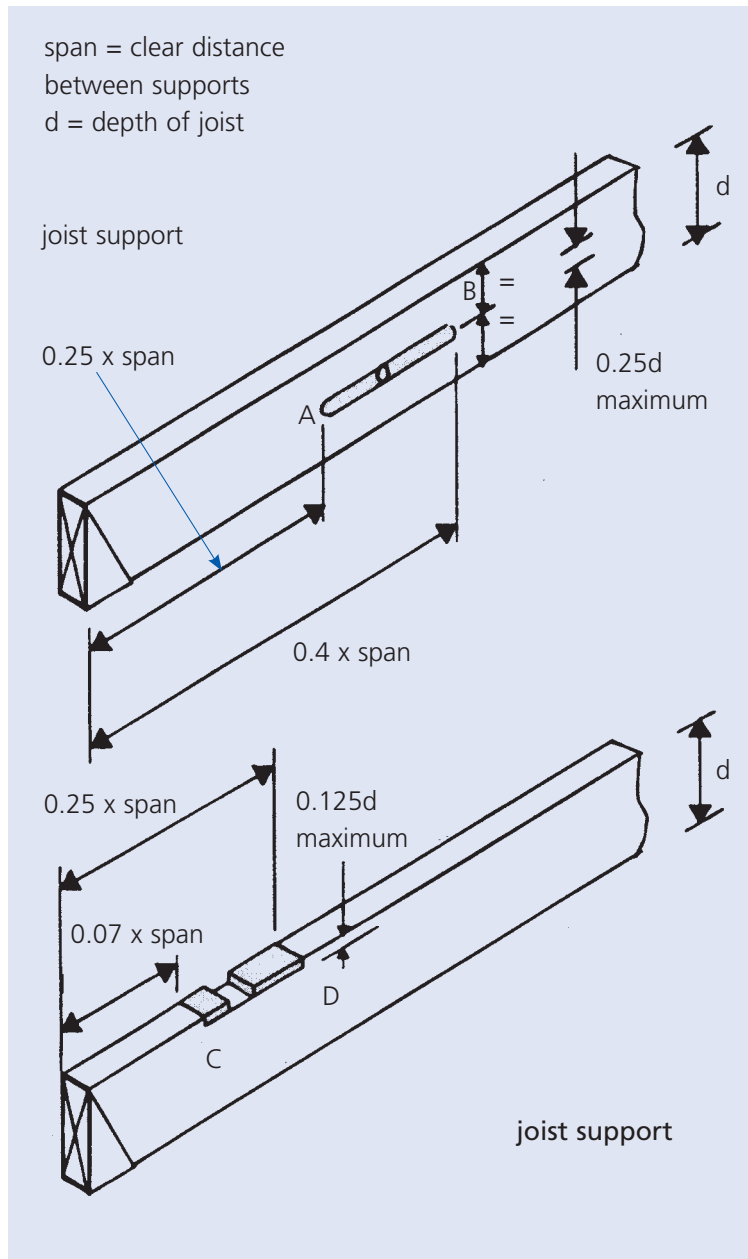

Notching and drilling joists

Zurich Building Guarantee

Zurich House, 2 Gladiator Way, Farnborough, Hampshire, GU14 6GB.

Telephone 01252 377474 Fax 01252 372989 Email building.guarantee@uk.zurich.com www.zurich.co.uk/buildingguarantee

Zurich Building Guarantee is a trading name of Zurich Insurance plc. A public limited company incorporated in Ireland. Registration No. 13460.

Registered Office: Zurich House, Ballsbridge Park, Dublin 4, Ireland. UK Branch registered in England and Wales Registration No. BR7985.

Authorised by the Irish Financial Regulator and subject to limited regulation by the Financial Services Authority. Details about the extent of our regulation by the Financial Services Authority are available from us on request. FSA registration number 203093. These details can be checked on the FSA's register by visiting their website www.fsa.gov.uk/register or by contacting them on 0845 606 1234.

Communications may be monitored or recorded to improve our service and for security and regulatory purposes. © Copyright – Zurich Insurance plc 2009.

All rights reserved. Reproduction, adaptation or translation without prior written permission is prohibited except as allowed under copyright laws.