

best practice sheet – chimneys

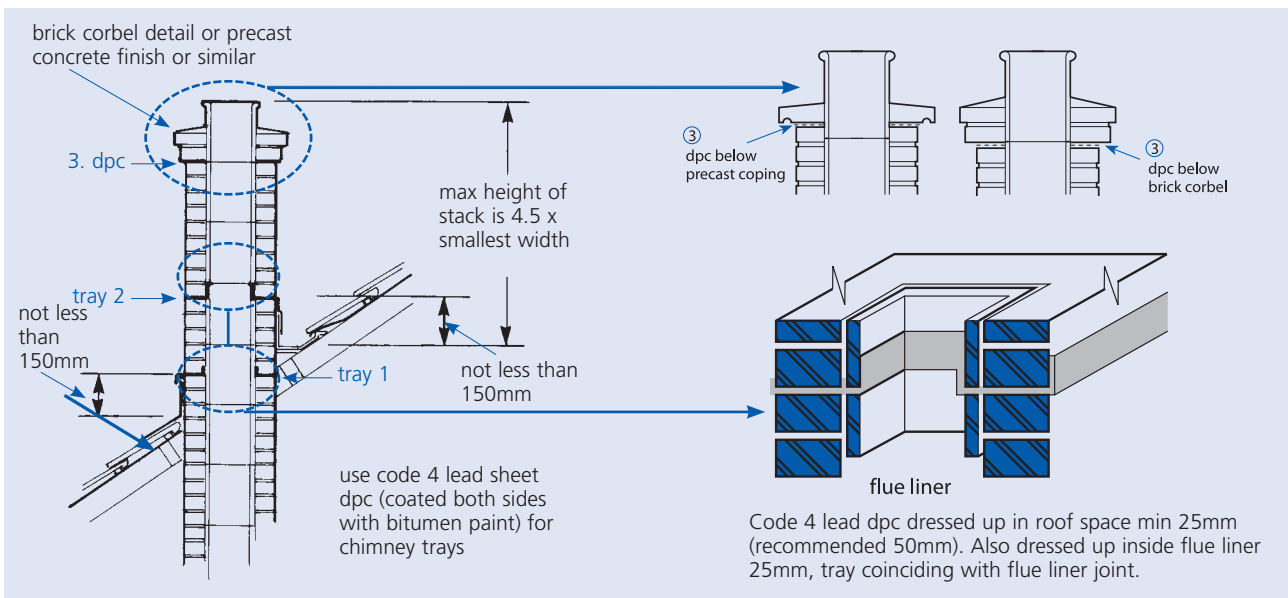

Position of lead trays in a typical chimney

Points to watch

1. Ensure that all gas flues terminate to the open air i.e. flue blocks must terminate at an appropriate ridge vent or similar even where no appliance is fitted prior to the sale /occupancy of the property.
2. Use code 4 lead sheet dpcs, coated both sides with bitumen paint, for tray positions 1 and 2 indicated above. For position 3 above, use either lead, engineering bricks or other dpc suitable for exposure below coping or brick corbel.
3. Provide a minimum of 2 No weep holes at the external front of each tray to release any moisture build-up.
4. The mortar mix, above the roof line, should generally be 1:2½-3½ (masonry cement : sand).
5. Flue liners to be used as specified with sockets upper most and jointed with fire resisting mortar.
6. The height of an unrestrained chimney should not be greater than 4½ times the least horizontal dimension of the chimney (for a minimum masonry density of 1500kg/m³). Chimneys should terminate outside the shaded areas indicated on the applicable diagram overleaf.
7. Provide code 4 lead dpc trays, lead flashing details and associated weep holes to external chimney breasts.

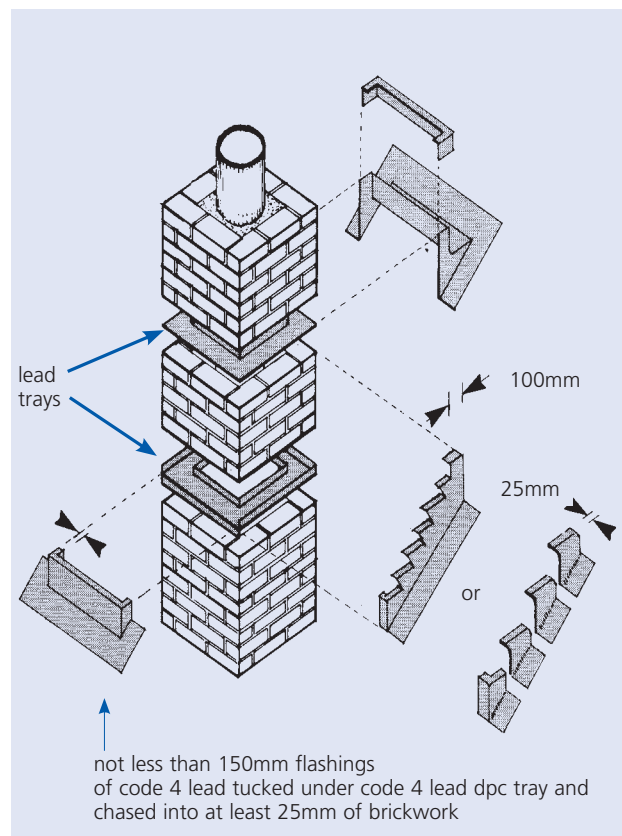

Lead flashing detail to a typical chimney

best practice sheet – chimneys

(continued)

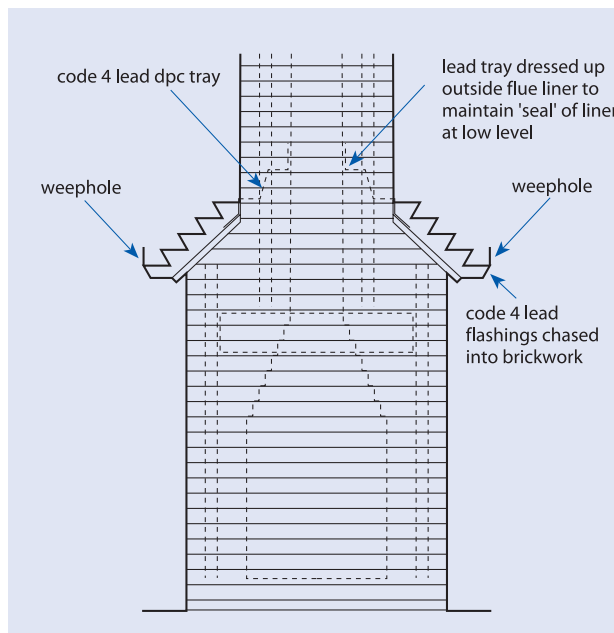

Lead Flashing and tray detail to a typical chimney breast

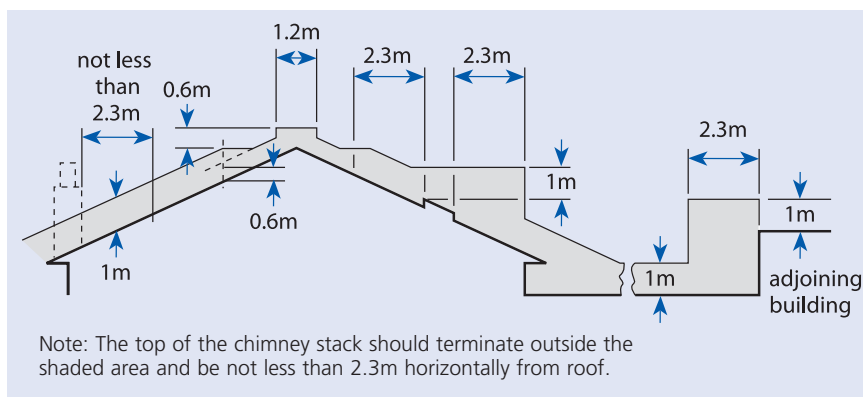

Minimum chimney heights

Zurich Building Guarantee

Zurich House, 2 Gladiator Way, Farnborough, Hampshire, GU14 6GB.

Telephone 01252 377474 Fax 01252 372989 Email building.guarantee@uk.zurich.com www.zurich.co.uk/buildingguarantee

Zurich Building Guarantee is a trading name of Zurich Insurance plc. A public limited company incorporated in Ireland. Registration No. 13460.

Registered Office: Zurich House, Ballsbridge Park, Dublin 4, Ireland. UK Branch registered in England and Wales Registration No. BR7985.

Authorised by the Irish Financial Regulator and subject to limited regulation by the Financial Services Authority. Details about the extent of our regulation by the Financial Services Authority are available from us on request. FSA registration number 203093. These details can be checked on the FSA's register by visiting their website www.fsa.gov.uk/register or by contacting them on 0845 606 1234.

Communications may be monitored or recorded to improve our service and for security and regulatory purposes.

© Copyright – Zurich Insurance plc 2009. All rights reserved. Reproduction, adaptation or translation without prior written permission is prohibited except as allowed under copyright laws.